



## 1.1kW Single Phase Automatic Controller

Single Phase, 240V (including Capacitor)  
for motors up to 1.1 kW



### Suitable Scales

This Automatic Controller is suitable to direct start the single phase electric motors under 1.1kw. The pump controller automatically controls the pump motor as well as providing comprehensive pump protection. It is easy to operate and safe.

### Serials and specifications

Power	Hp	0.55	0.75	1	1.5	2	3
	Kw	0.37	0.55	0.75	1.1	1.5	2.2
Rated Current	A	3.9	4.8	6.5	8.6	10.9	14
Capacitor	μF	15	20	25	35	45	50

### Mains Functions

- There is no need for any adjustment to control the water level.
- Anti high voltage designed in water level control circuit board

### Main Technical Specifications

- Suitable electric power: single phase alternating current, alternate 240V ± 5%, 50Hz
- Static power loss of the controller: <3W
- Water level pole voltage: direct 12V
- Allowed maximum resistance of pole line: 30kΩ

### INSTALLATION

#### Ordinary Installation

The controller should be well ventilated but protected from direct sunlight, rain, strong vibration, tinder and explosive goods.

Connect the wires according to the instruction manual and connecting diagram.

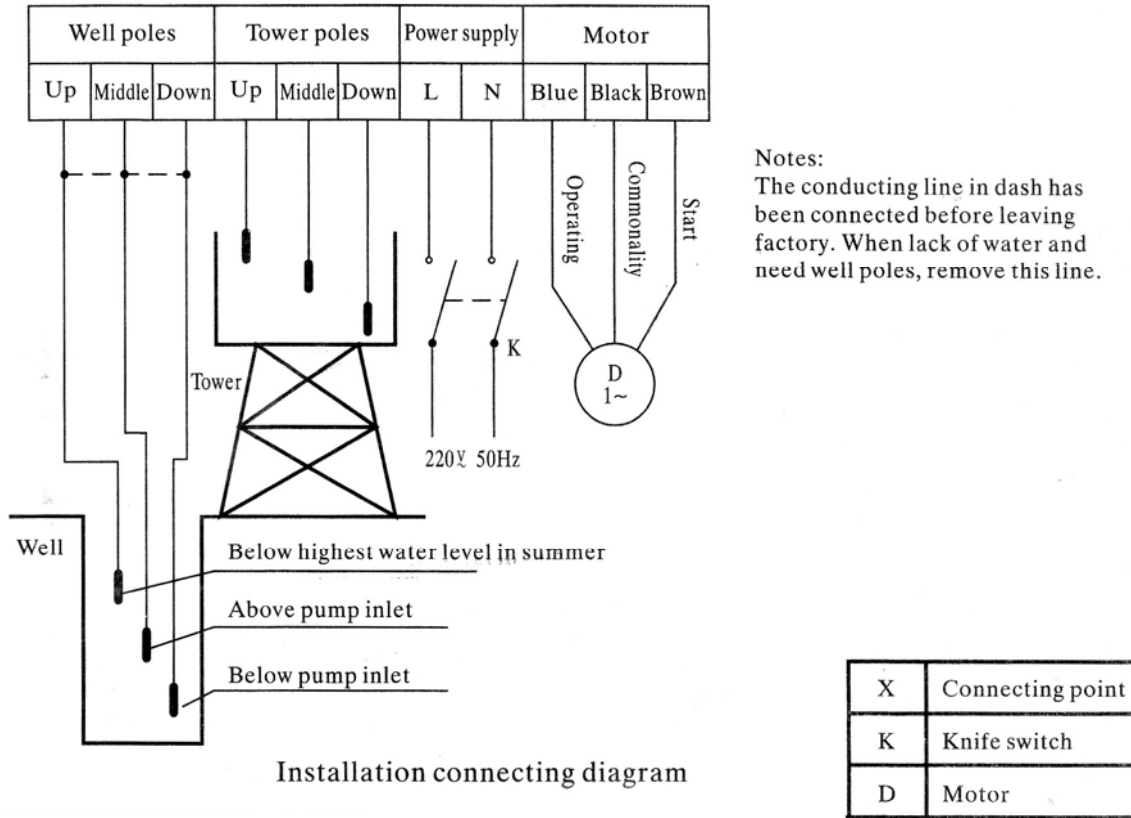

### Liquid Level Automatic Installation

- When using the water level automatic control, it is necessary to place the water level pole conduct line and poles.
- If there is enough water in the well and no chance the water level will be lower than the inlet of the pump, there is no need to install well poles (which is short by conductor at the connectors before leaving the factory. Otherwise the conductor should be removed).
- Placement of Poles
  - Well low pole: This is the water level feedback signal pole. Usually use metal drainage tube connected to the shell of the pump to replace the pole. If the drainage tube is not metal, the low pole must be placed under water level.
  - Well middle pole: This is the automatic cut-off signal pole when the well is short of water (low water level). It is placed above the inlet of the pump. It should not be too high in order to fully use the well water.
  - Well up pole: This is the reset to automatically start motor signal pole (upper water level). It should be placed under the highest level at low water season (otherwise the motor cannot automatically start when the level will not reach the level). At the same

time, it should be as far away from the middle pole as possible in order to reduce the start and cut off times of the pump.

- Tower low pole: This is the water level feedback signal pole. It is usually placed at the bottom of the tower.
- Tower middle pole: This is the automatic cut-off signal pole when the tower is short of water (low water level). It is usually placed below the middle place of tower.
- Tower upper pole: This is the motor cut off signal pole when the tower is full of water (upper water level). It is placed below the spillover port, above the middle pole.

Note, there is no short contact between the poles. The pole metal parts should not contact metal tube or well wall.

#### Adjustment of poles

- For wells, the upper pole is mainly adjusted and should not be fastened so as to adjust when not sure of the highest level at low water season.
- For tower, the middle pole is mainly adjusted. When its position is too high, the pump will pump water too soon and the tower has enough water for peak supply but the motor will start and cut off too frequently (affecting the life of the motor). When its position is too low, the motor start time can be reduced, but the tower may not have enough water for peak water supply. It can be adjusted according to real conditions.

#### Usage

Preparation before running controllers: Before starting the motor, carefully check that the connections are correct, voltage is normal, etc.

Manual control: It is better to use automatic manual for manual control. Manual control should not be used as often. When there is something wrong with the circuit board and water is needed to be pumped, the manual control should be used.

Liquid level control: After the poles and pole lines are installed, the controller should be at the 'automatic' position to start the motor. The start and stop of the pump motor is controlled by the signal feedback by water level poles and usually without any other operation. When there is a new installation or maintenance stage, the automatic controlling function can be checked by simulating the water level up and down.

#### Notify Items

Carefully read this instruction manual before using the controller.

Operators should possess electrical and mechanical knowledge. Install and use the controller under electrical safe operation specifications.

High level cells should have good lightning protection apparatus.

When there is a thunder storm it is better to cut off the power. Stop us in case it caused damage to the controller.

When the motor is automatically stopped as a fault of the device, do not start the motor again until the fault is rectified preventing the fault from worsening or the motor burning out.

**Overview of ordinary faults**

Motor is running without draining water		<ol style="list-style-type: none"> <li>1. Pump rotates in reverse</li> <li>2. Connector between the motor and the pump is broken</li> <li>3. Draining tube inside the well is loose</li> </ol>	<ol style="list-style-type: none"> <li>1. Exchange any two power lines</li> <li>2. Repair or change the connector</li> <li>3. Connect draining tube</li> </ol>
Output amount of water is unstable		<ol style="list-style-type: none"> <li>1. Pump drainage amount is too big and there is a lack of water</li> <li>2. Pump not placed deep enough so that there is a lack of water</li> <li>3. Well moves water level lower than the pump inlet</li> </ol>	<ol style="list-style-type: none"> <li>1. Change the pump to one that has a suitable amount of drainage</li> <li>2. Lower the pump height</li> <li>3. Change to a smaller pump or turn outlet valve down</li> </ol>
Manual position does not work properly	Cannot Start	<ol style="list-style-type: none"> <li>1. No power supply</li> <li>2. Circuit line inside controller is loose</li> <li>3. Relay coil is broken</li> <li>4. Circuit board is damaged</li> </ol>	<ol style="list-style-type: none"> <li>1. Check the power supply</li> <li>2. Check and connect circuit line inside controller</li> <li>3. Change relay coil</li> <li>4. Change new circuit board</li> </ol>
	Cannot Stop	<ol style="list-style-type: none"> <li>1. Contacting point of alter relay is burned together</li> <li>2. Contacting point of sensing relay in board is burned</li> </ol>	<ol style="list-style-type: none"> <li>1. Change alter relay (or contacting point)</li> <li>2. Change new board</li> </ol>

		together	
Auto Position not working properly	Cannot Automatically start	<ol style="list-style-type: none"> <li>1. When no well poles, well poles at connecting side not short</li> <li>2. Well poles broken or loose</li> <li>3. Tower poles shortage or upper, middle pole contacted the wall</li> <li>4. Well upper pole too high, water cannot reach</li> </ol>	<ol style="list-style-type: none"> <li>1. Connect pole short line</li> <li>2. Check and connect well pole line</li> <li>3. Check and solve short circuit problem, hang pole in the air</li> <li>4. Lower well upper pole height</li> <li>5. Repair board or change new board</li> </ol>
	Cannot stop automatically	<ol style="list-style-type: none"> <li>1. Tower pole line is broken or loose</li> <li>2. Short circuit between well poles or upper pole or middle pole contacting earth</li> <li>3. Circuit board is damaged</li> </ol>	<ol style="list-style-type: none"> <li>1. Check and connect</li> <li>2. Check and change pole lines, place pole right</li> <li>3. Change board or repair board</li> </ol>